

REVISION HISTORY			
REV	DATE	BY	DESCRIPTION
C	19APR2019	JQ/LC	PRN: P2019-1029

NOTES:

A. INSTALLATION INSTRUCTIONS:

1. DRILL OR PUNCH $\varnothing 9.12 \pm 0.08$ HOLE IN OUTER PANEL.
2. PRESS STUD FIRMLY TO HOLD TEETH OF FERRULE AGAINST PANEL. THREAD SLEEVE NUT INTO FERRULE AND TIGHTEN WITH WRENCH SOUTHCO PART NUMBER 56-0-22041-04.

B. MATERIAL AND FINISH:

1. STUD: HARDENED STEEL, ZINC PLATE PLUS SEALER.
2. KNOB: PC/ABS, UL94 V0 RATED.
3. SPRING: 300 SERIES SATINLESS STEEL, PASSIVATED.
4. END CAP, FERRULE AND SLEEVE NUT: STEEL, ZINC PLATED PLUS SEALER.

C. COSMETIC SPECIFICATION: ALL SURFACES (UNLESS OTHERWISE SPECIFIED) ARE TO BE PER SOUTHCO SPECIFICATION S-121-02, CLASS B, FERRULE AND SLEEVE NUT CLASS C.

D. PARTS SHIPPED BULK.

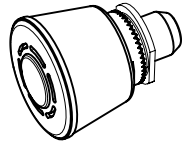

SCALE 1:1

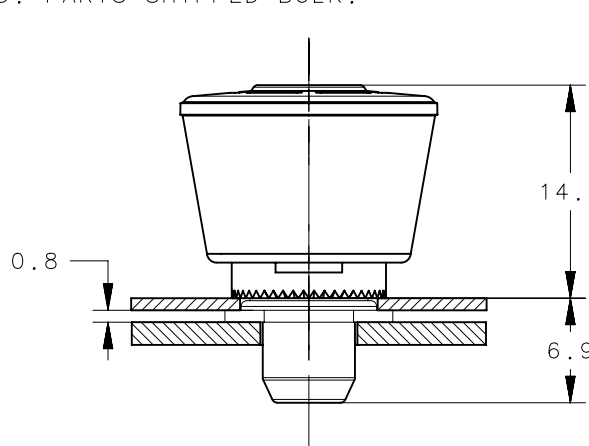
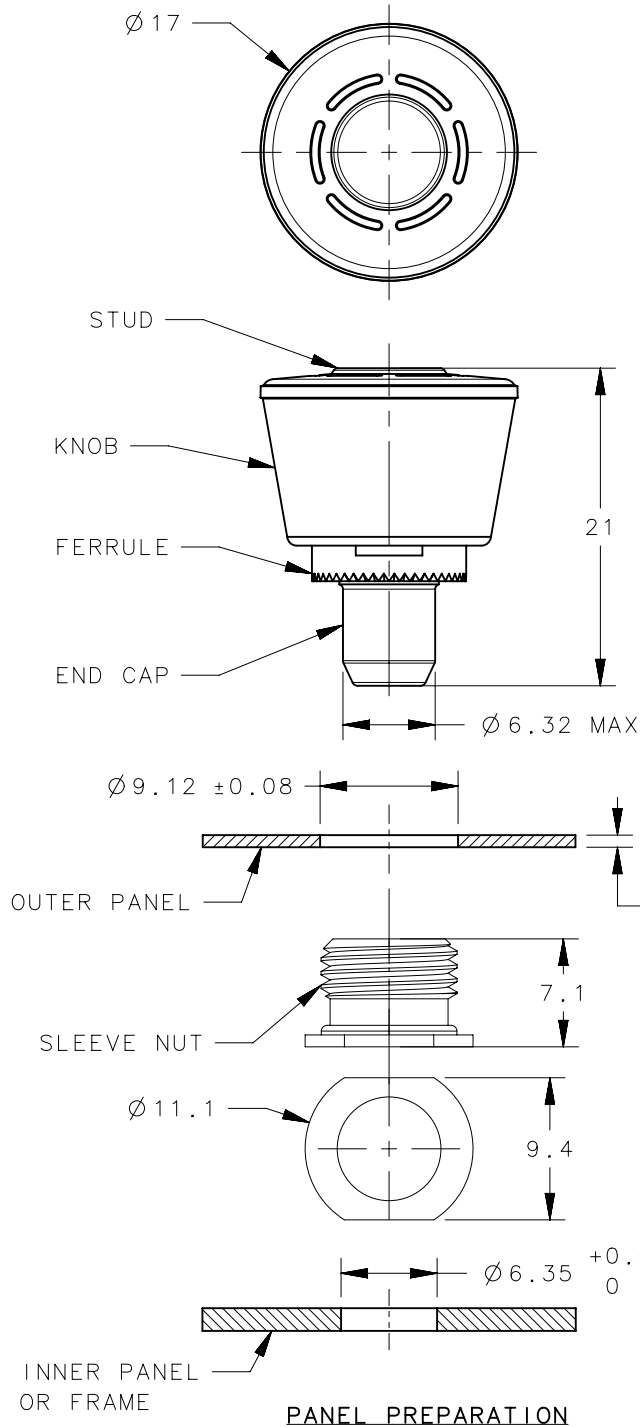

RELEASED

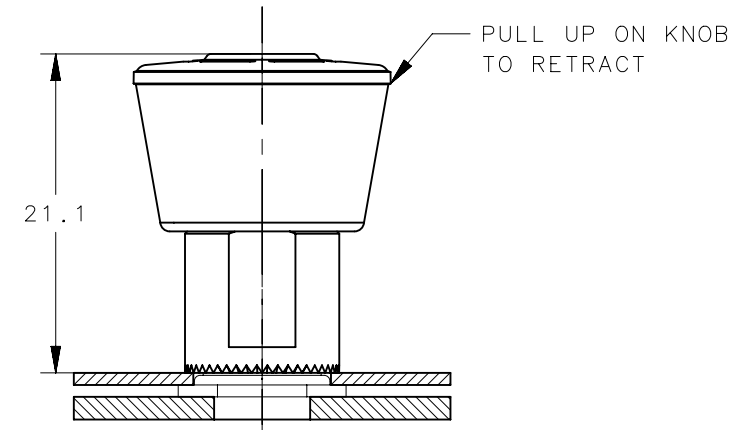

RETRACTED

EEE KNOB COLOR

000 BLACK

SEE J-47-0-3 FOR DETAIL

56-280-EEE	ASSEMBLE	SEE NOTES	SEE NOTES
PART NUMBER	TYPE OF COMPONENT	MATERIAL	FINISH

	THIRD ANGLE PROJECTION	
	MILLIMETERS [IN]	
	TOLERANCES UNLESS OTHERWISE NOTED	
SURFACE AREA	UP TO 0.5	±0.1
	OVER 0.5 UP TO 6	±0.2
VOLUME	OVER 6 UP TO 30	±0.4
	OVER 30	±0.6
	ANGLES	±5°
	PER ASME Y14.5M-1994	

southco [®]			
CONNECT • CREATE • INNOVATE			
DESCRIPTION			
56 PLUNGER			
THREAD-IN, PRISM-LARGE			
SIZE	SYSTEM	DWG NO.	
A4	NX	J-56-280	
DRAWN BY	DATE	SCALE	SHEET
JQ/LC	29MAR2018	2:1	1 OF 1

PROPRIETARY ITEM
EXCEPT FOR USES EXPRESSLY GRANTED
IN WRITING, INFORMATION DISCLOSED
HEREON IS CONFIDENTIAL AND ALL
RIGHTS, PATENT AND OTHERWISE,
ARE RESERVED BY SOUTHCO, INC.