

# southco

PROPRIETARY ITEM - EXCEPT FOR USES EXPRESSLY GRANTED IN WRITING, INFORMATION DISCLOSED HEREON IS CONFIDENTIAL AND ALL RIGHTS PATENT AND OTHERWISE ARE RESERVED BY SOUTHCO, INC.

## No B7 LOCKING SLIDE LATCH ASSEMBLY

DATE	DRAWN	CHKD	SCALE	DRAWING NUMBER
2-7-77	ACZ		.75 : 1	J-B7-20-501-10

REV.	DATE	DRAWN	REVISION
H	18DEC2001	JPW/JSS	PRN: P2001-0337

ITEM	COMPONENT	PART No	MATERIAL	FINISH
ASSEMBLY		B7-20-501-10		
	SLIDE		NYLON	BLACK
	HOUSING		1010 STEEL	SEE NOTE "B"
	SPRING		302 STAINLESS STEEL	PASSIVATED
	STUD		LOW CARBON STEEL	SEE NOTE "C"
	WASHER		ACETAL	BLACK
	LOCK ASS'Y		SEE NOTE "A"	SEE NOTE "A"

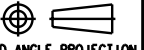
INCH DIMENSIONS
DIMENSIONS WITHOUT TOLERANCES ARE FOR REFERENCE ONLY.
 THIRD ANGLE PROJECTION
A4 PAPER SIZE

### INSTALLATION INSTRUCTIONS:

- PREPARE PANEL AS SHOWN. NOTE MAX FRAME AND PANEL THICKNESSES.
- ATTACH FASTENER TO PANEL USING FOUR  $\phi$ .25 RIVETS OR SCREWS. ALTERNATIVE: WELD HOUSING IN PLACE.
- PLACE LOCK IN OPENING AND SECURE WITH HEX NUT. WITH KEY IN LOCK, ORIENT LOCK CYLINDER TO UNLOCKED POSITION. ATTACH LOCK PAWL IN PROPER ORIENTATION WITH SCREWS PROVIDED.

### NOTES:

- LOCK ASSEMBLY CONSISTS OF:  
CYLINDER - DIE CAST ZINC, BLACK POWDER COATING;  
LOCK PAWL - 1010 STEEL, ZINC PLATE, CHROMATE PLUS SEALER;  
KEYS - BRASS, NICKEL PLATED;  
HEX NUT - DIE CAST ZINC, CHEMICAL PROTECTIVE FILM.
- BLACK POWDER COATING.
- ZINC ALLOY PLATE, BRIGHT CHROMATE PLUS SEALER.

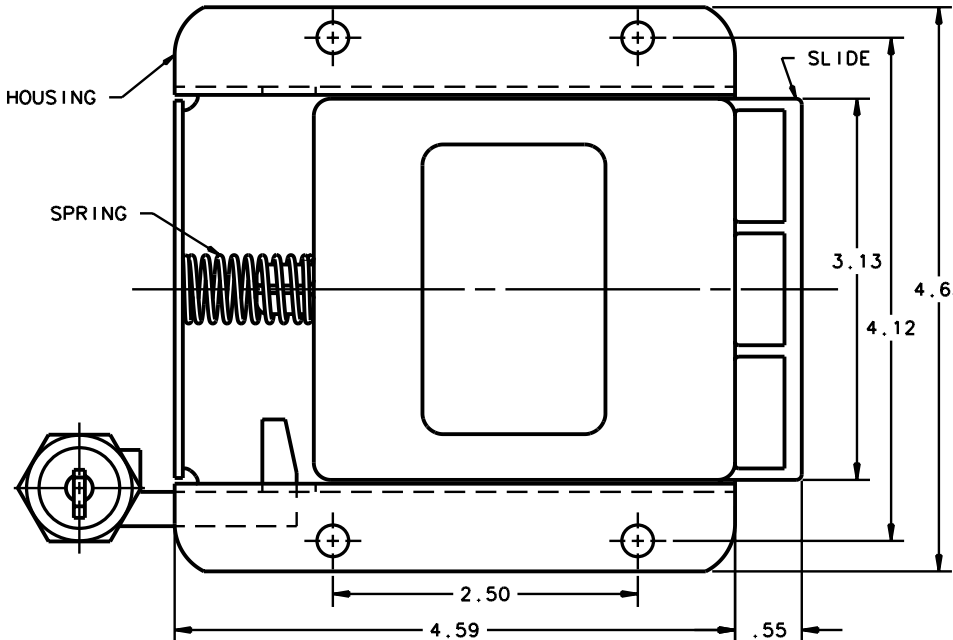

### PANEL PREPARATION SCALE .33 : 1

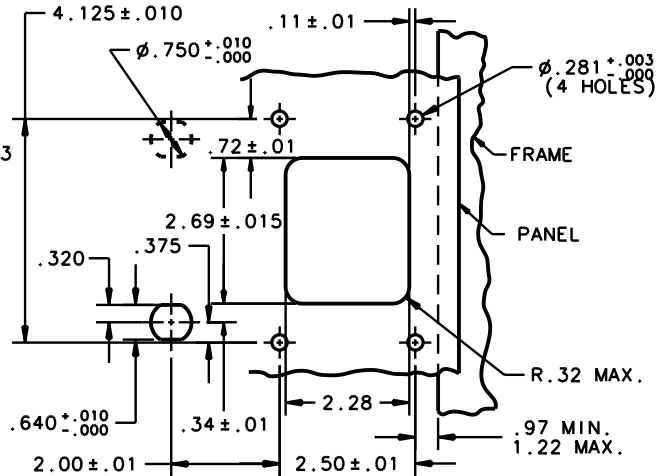

MOUNTING NOTE:  
LOCK ASSEMBLY MAY BE MOUNTED ON EITHER SIDE OF FASTENER.

