

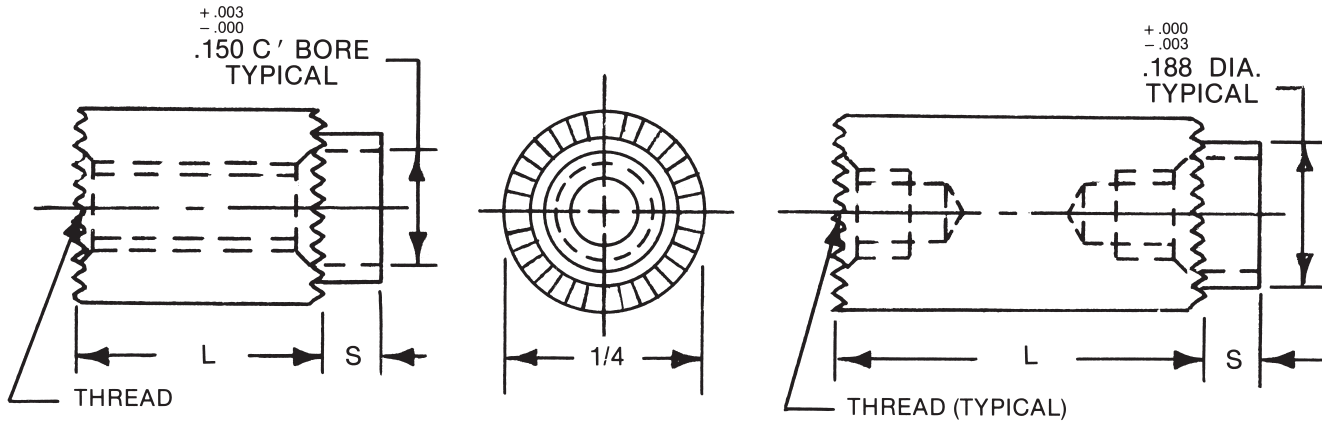

1/4 ROUND KNURLED DOUBLE FACE SWAGE STANDOFFS



See page 10 for thread depth chart
 See page 9 for finish codes
 For non-standard parts contact Sales Office

L = STANDOFF LENGTH
 S = SHANK LENGTH
 P = BOARD THICKNESS

See page iv for installation information

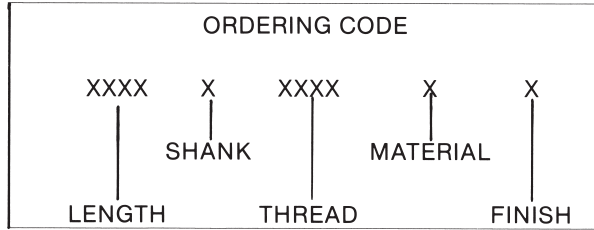

SWAGE TOOLING		
PUNCH	ANVIL	LENGTH
P-4	AR-22	1/8-3/16
	AR-23	1/4-7/16
	AR-24	1/2-11/16
	AR-25	3/4-2"

SWAGE/PANEL CODE		
± .003	S	P
.075	A	1/32
.105	B	1/16
.135	C	3/32
.165	D	1/8

LENGTH	PART NO.
1/8	7827
3/16	7828
1/4	7829
5/16	7830
3/8	7831
7/16	7832
1/2	7833
9/16	7834
5/8	7835
11/16	7836
3/4	7837
13/16	7838
7/8	7839
15/16	7840
1"	7841

LENGTH	PART NO.
1-1/16	7842
1-1/8	7843
1-3/16	7844
1-1/4	7845
1-5/16	7846
1-3/8	7847
1-7/16	7848
1-1/2	7849
1-9/16	7850
1-5/8	7851
1-11/16	7852
1-3/4	7853
1-13/16	7854
1-7/8	7855
1-15/16	7856
2"	7857

THREAD	CODE
4-40	440
6-32	632

MATERIAL	CODE	RoHS
Aluminum	AL	YES
Brass	B	YES
Stainless Steel	SS	YES
Steel	S	YES



95 Silvermine Road, Seymour, Ct. 06483 Phone: 203-888-2133 Fax: 203-888-9860
 e-mail: info@rafhdwe.com Web: www.rafhdwe.com

