

PART NO.
SLPL438A

PROPRIETARY NOTICE
 "THIS DRAWING CONTAINS DESIGN AND OTHER INFORMATION WHICH ARE THE PROPERTY OF VLIER. THIS DRAWING MAY NOT, IN WHOLE OR IN PART, BE REPRODUCED OR USED FOR PURPOSES OF MANUFACTURE, OR OTHERWISE, WITHOUT THE PRIOR WRITTEN PERMISSION OF VLIER. ANY COPIES OF THIS DRAWING DISTRIBUTED FOR INFORMATIONAL PURPOSES, WHETHER UNDER THE TERMS OF A CONTRACT OR OTHERWISE, ARE TO BE RETURNED TO VLIER ON REQUEST OR WHEN THE PURPOSE FOR WHICH THEY WERE ISSUED IS ACCOMPLISHED. VLIER WILL TAKE ALL NECESSARY ACTION TO ENFORCE IT'S RIGHTS TO THIS PROPRIETARY INFORMATION."

REVISIONS

ZONE	LTR	DESCRIPTION	DATE	APPROVED
	B	PER ECO 0308012	LF 12/11/03	TG 12/11/03

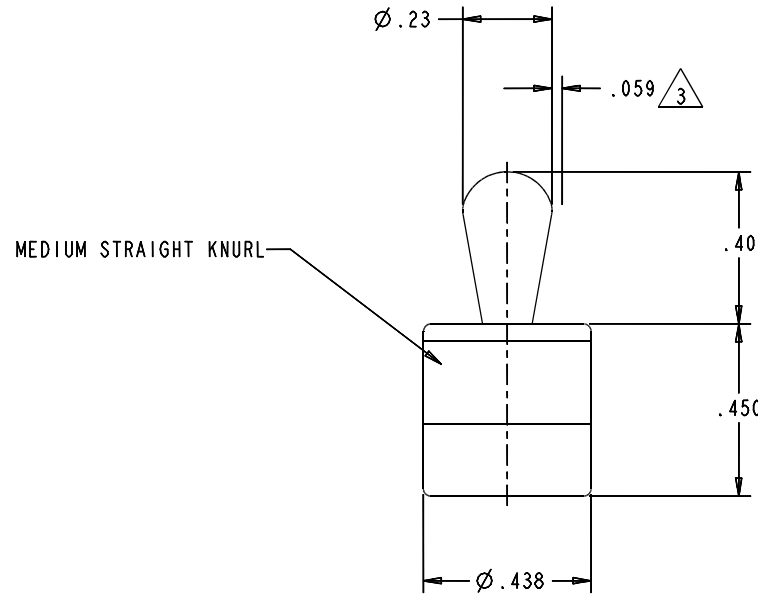
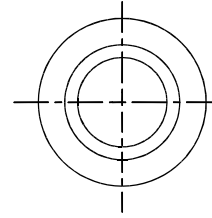

NOTES:

- 1 MATERIAL:
 BODY - ALUMINUM
 PIN - STEEL
 SPRING - MUSIC WIRE
 SEAL - NEOPRENE
- 2 FINISH:
 BODY - GOLD IRIDITE
 PIN - BLACK OXIDE
 SPRING - GOLD IRIDITE
 SEAL - NONE
- 3 APPROXIMATE FORCE REQUIRED TO LATERERLY MOVE PIN .059 AS SHOWN IS 9.0 LBS.

QTY	RECD	FSCN NO.	PART NUMBER	DESCRIPTION	MATL/NOTE	SPEC/NOTE
PARTS LIST						
UNLESS OTHERWISE SPECIFIED: REMOVE BURRS & SHARP EDGES SURFACE ROUGHNESS ✓ DIMENSIONS APPLY AFTER FINISH CALLOUTS IN () ARE SI UNITS DIMENSIONS ARE IN INCHES TOLERANCES: DECIMALS .X± .03 ANGLES .XX± .015 ± 0° 30' .XXX± .005 DO NOT SCALE DRAWING			CONTRACT NO.		VLIER VLIER Brighton, Massachusetts 02135 A DIVISION OF HUTCHINSON®	
NEXT ASSY		FINAL ASSY		PREPARED	DATE	
				T. E. GODDARD	9/31/98	
MATERIAL		APPLICATION		CHECKED	DATE	
1		1		R. LEZBERG	11/16/98	
FINISH		THIRD ANGLE PROJECTION		ENGINEER	DATE	
2				C. COUGHLAN	11/16/98	
				MANUFACTURING	SIZE	FSCN NO.
				D. LOGAN	C	01226
				QUALITY ASSURANCE	DWG NO.	
				A. KURUVILLA	11/16/98	
				SCALE 4.000		SHEET 1 OF 2